



SWIMEX

ARCHITECT INSTALLATION GUIDELINES FOR COMMERCIAL TRITON INSTALLATIONS

GENERAL LAYOUT

- Call SwimEx at 800-877-7946 to receive AutoCAD® Drawings of the SwimEx Triton model that you will be installing. These drawings can be placed directly into your pool room layout and site drawings.
- The SwimEx Triton model comes standard in one piece. (No seams or additional assembly of pool sections are required)
- Provide a flat level surface for pool to sit on with a load-bearing capacity of 425 lbs./sq.ft. (2075 kg/sq.m) *Footprint of pool must be level, remainder of pit or area can be sloped to drain water.*
- Below ground installation requires a minimum pit of 9' (2.74m) wide by 20' (6.096m) long and 56" (1.42m) deep for SwimEx Triton model. The pit side walls provide no structure for the pool; they are only retaining walls.
- In ground and semi in-ground applications should have a minimum of 7' (2.13m) above the pool rim and deck to the ceiling. Above ground installation requires a minimum ceiling height of 10'(3.04m). In both cases we recommend no obstructions above the pool (Lights, vents, ducts, beams) *Check local building codes for minimum ceiling height and required decking area.*
- Every SwimEx Triton comes standard with an entrance ladder. The ladder needs to be placed in the optimum location based on the orientation of the pool within the room. Please familiarize yourself with the SwimEx Triton orientation, and make sure that the order specifies whether the ladder should be on the right or left side. The ladder can be placed on either side of the unit for no charge, so long as the order indicates the location. (The entrance ladder is formed in the molding process; thus we must know the desired location at the time the order is placed.)
- Allow access to equipment and pool via access hatch for in ground, or access panels for above-ground installations. A ladder should be provided to access the pump, filter and heater located within the pit.

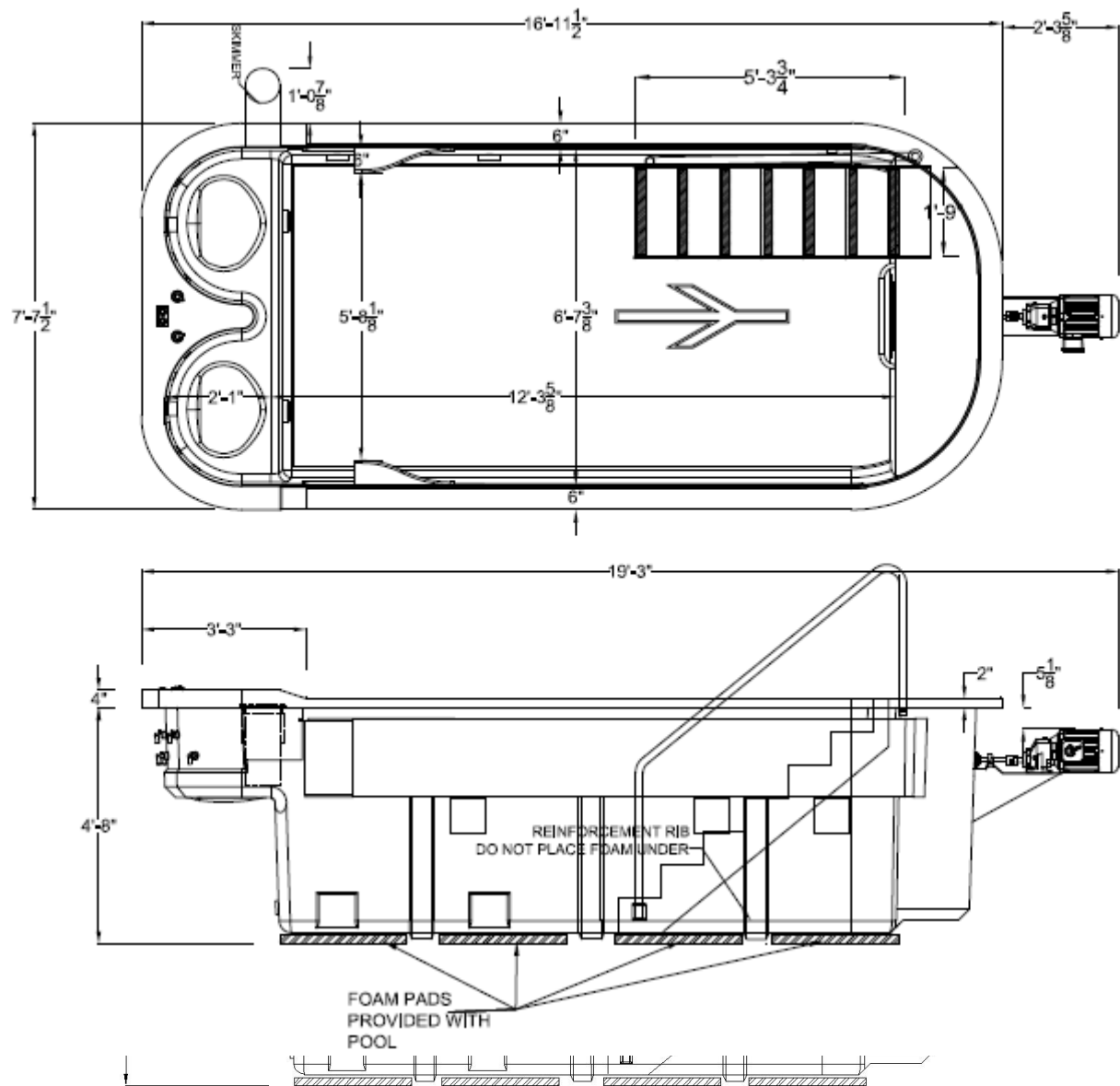

Delivery Requirements

- Clear passage for 18-wheel tractor trailer truck to deliver, and forklift or crane on site to off-load pool from truck. Please review Shipping Section of Manual. If site is not accessible by tractor trailer, this must be specified for special freight quotes.
- Planning must be done so that this can occur early in the construction process to have complete access to the area. (*Crane provided by owner*) A clear, unobstructed work area in and around the pit must be provided for movement of the Triton into the pit. *No decking shall be constructed until the pool has been filled and water tested.*

Once the pool has been filled and water tested, then the decking can be constructed around the SwimEx Triton. This is not part of the SwimEx Triton assembly, unless the prefab skirting option is ordered. Please refer to Deck Construction Section of the Manual for instructions.

Electrical Requirements:

- Standard pool requires 220/240 Volt, single phase, 115 Amps GFCI Breakers to be provided by electrician

Propeller Controller:

5 HP Pools 70Amp 208/240V Single Phase (54 FLA)

Heater: 30 Amp 240V Single Phase (23 FLA)

Pump: 15 Amp 240V Single Phase

- Must provide sub panel with appropriate GFCI breakers for equipment
- *Please refer to Electrical Schematic in Electrical Section of the Manual*
- Variable speed controller takes 220/240 Volt single phase in and converts to 3-phase to drive the motor.
- Electrician, in accordance with local and national electric codes, must make all connections between equipment and circuit breakers.
- Connections to be made dealing with the SwimEx Triton are from the breaker panel to the variable speed controller, controller to motor, breaker panel to heater, and breaker panel to pump. These must be done on site by an electrician contracted by owner.
- Conduit needed from Variable Speed Controller to poolroom near front of pool for EDGE Touch Screen Monitor. Conduit must be able to let a 7/8" (2.22cm) diameter connector pass through. The location of the EDGE Touch Screen Monitor must be 5' (1.52m) away from the pool and should be determined by the end user of the pool.

Other Equipment Considerations – Optional SwimEx equipment:

Please refer to Other Equipment Assemblies Section of the Manual

- **Underwater Lights:** 110 Volt plug in unit on right or left side of pool. Provide switch to turn off and on in convenient location for owner
- **Jet Option:**
Jet Pump 120/240V 1 HP pump controlled through ES Combo Switch
- **Ozonator:** 110V plug in unit. Should be connected through same line as Pump to ensure that it shuts off when pump is turned off.

Non SwimEx Equipment provided by owner

Sump Pump: Plumber will locate a sump pump within pit area, connection means must be provided for.

Lights under deck or in pit area: Pit area must have lights for future maintenance.

Mechanical Requirements:

Please read and familiarize yourself with the Plumbing Section of the Manual

- **Plumbing:**

Pool is pre-plumbed with all eyeball and suction fittings. On site plumber (contracted by owner) must make connections between pool and provided pool equipment. All connections are PVC and will vary depending on location. Typical connections are schedule 40 PVC and range from 1 ½" (3.81cm) to 2" (5.08cm) in diameter.

- **Water Fill:**

¾" (1.9cm) Cold Water fill line for pool (Tempered water can be provided but is not required). The fill line must be protected by backflow preventers as required by local codes.

Valve for water fill should be located within poolroom so that operator can see water level as pool is being filled.

- **Drain:**

The SwimEx comes with a 2" (5.08cm) drain connected to the section of the pool with a shutoff valve. A small sump pump is provided for the remaining water in the pool. Drain will have approximate flow of 80 GPM (302.8 LPM) when pool is full.

- **HVAC:**

SwimEx recommends the use of a small dehumidifier within the pit area to keep moisture out. This area is generally below ground and occasionally gets wet due to splashing and/or cleaning of the filter.

If the room is air conditioned, we recommend that there be no air intake back to the rest of the buildings system. Cross contamination of air is possible.

Ventilation and exhaust from Pool Room: The small water area exposed to the air eliminates the need for large dehumidification systems. Typical water loss due to evaporation is in the range of 4-6 lbs. (1.81-2.72 kg)/ hour for a standard SwimEx pool.

Standard Pool Equipment

The following is the standard equipment for the Triton Model.

Pump

Pentair Pool Products

Model: Intelliflo VSF Variable speed Pump
208-240V 1 phase 20 Amp GFCI Circuit required
Up to 145 GPM (511 LPM) @ 60TDH
2940 Gallons (11,129L) turnover at 120 GPM: 24.5 minutes
NSF Listed

Filter

Pentair Pool Products

Model: Clean & Clear Plus CCP-320
320 Sq.ft. (29.7sq. m) of cartridge area
Flow rate at .375 GPM/sq. ft (1.41 LPM/.09 sq. m). is 120GPM (454 LPM)
2" (5.08 cm) Socket union type connections
Dimensions: 21.5" (546mm) diameter by 43" (1092mm) tall

Heater

Coates Model 12406T 5.5 Kw Electric Heater
Electrical requirements: 30Amps @240V. (23 FLA)
Dimensions: 17 1/2" (444.5mm) x 4" (101.6mm) x 14 1/2" (368.3mm)